

5307 Series T-1 3/4 Right Angle LED Assembly
DESCRIPTION AND FEATURES

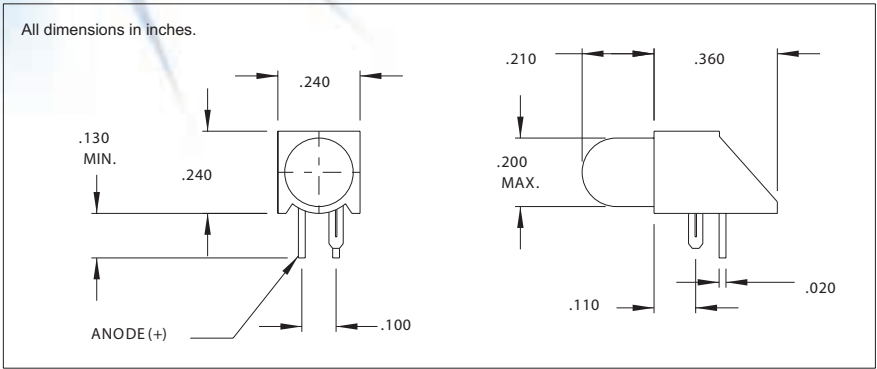

- Features**
- Press-in pin design holds block in place while being soldered.
 - Block mounting, low profile design, height & spacing alignment save assembly cost.
 - Super Brite LEDs-high intensity light output, diffused lens.
 - Built-in resistor chip operates off 5V supply without external resistor.
 - Standoffs prevent flux entrapment.

Housing: Black Nylon, UL94V-0

Alternate LEDs are also available in this package as a standard variation. Mounting hole pattern on page 1-X6.

ELECTRO-OPTICAL CHARACTERISTICS AND RATINGS

Part Number	Color	Typ. Intensity (mcd)	Rated Current (mA)	Continuous Forward Current Max. (mA)	Forward Voltage Typ. (V)	Forward Voltage Max. (V)	Peak Forward Current @ 1ms-300pps (A)	Reverse Break-down Voltage Min. (V)	Peak Wavelength (nm)
5307H1	Red	6.3	10	60	2.0	3.0	1.0	5	650
5307H3	Amber	10	10	60	2.0	3.0	1.0	5	608
5307H5	Green	10	10	60	2.2	3.0	.09	5	563
5307H7	Yellow	6.3	10	60	2.1	3.0	1.0	5	585
5307H1LC	Red	2.3	2.0	7	1.8	2.2	.007	5	635
5307H5LC	Green	2.3	2.0	7	1.8	2.2	.007	5	565
5307H7LC	Yellow	2.1	2.0	7	1.9	2.7	.007	5	583
5307H1-5V	Red	8	10	15	5	7.5	-	5	635
5307H3-5V	Amber	8	10	15	5	7.5	-	5	583
5307H5-5V	Green	8	12	15	5	7.5	-	5	565